

PK 7001-K

High Performance

PALFINGER CRANE

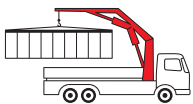

Powerful partner for municipal jobs

The PK 7001 K is perfectly suited for municipal jobs. Whether it's employing its clamshell bucket, moving small construction equipment or handling construction material, the crane accomplishes the job reliably and with maximum speed. And thanks to PALFINGER's functional design, the crane also offers operators easy-to-use controls.

With integrated
return oil utilization

KP-HPK7001KL1+E
E 06/08, K 06/08, D 06/08

PK 7001 K High Performance

STD

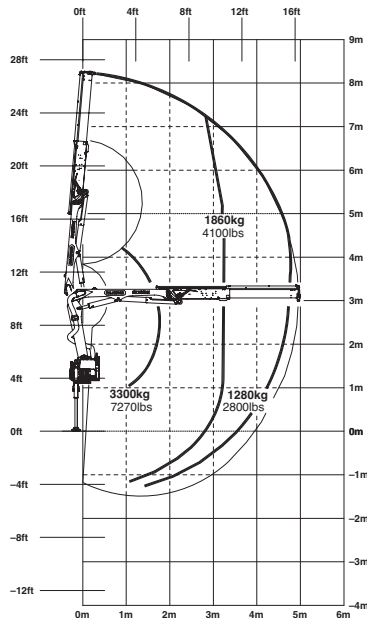

A

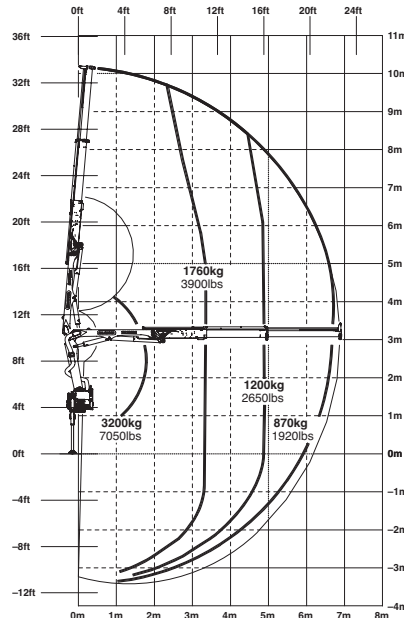

Technical Specifications (EN 12999 H1-B3)

Max. lifting moment	6.1 mt/59.8 kNm	44140 ft.lbs	Stabilizer spread	std. 3.0 m/9' 10"	max. 5.0 m/16' 5"
Max. lifting capacity	3300 kg/32.4 kN	7270 lbs	Fitting space required (std.)	0.66 m	2' 2"
Max. hydraulic outreach	6.9 m	22' 8"	Width folded	2.20 m	7' 3"
Max. manual outreach	10.9 m	35' 9"	Max. operating pressure	320 bar	4640 psi
Slewing angle	400 °		Recommended pump capacity	from 20 l/min	5.3 US gal./min
Slewing torque	0.8 mt/7.8 kNm	5790 ft.lbs		to 30 l/min	7.9 US gal./min
			Dead weight (std.)	726 kg	1600 lbs

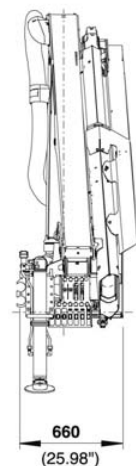
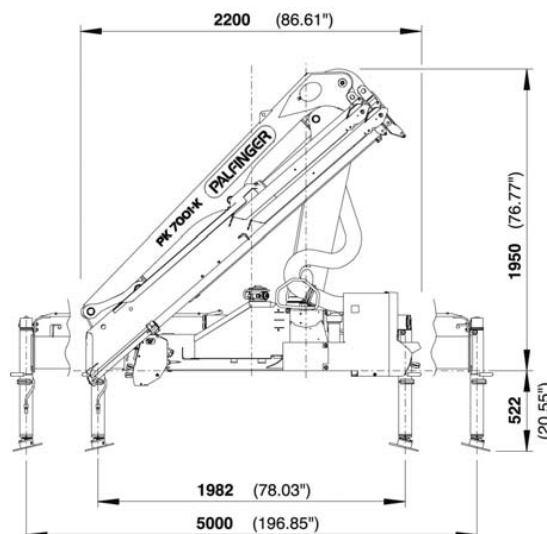
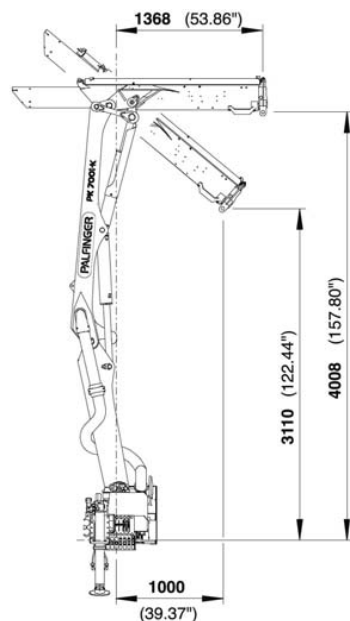

www.palfinger.com

Applications shown in the leaflet do not always correspond to the standard specifications. Design and specification are subject to change without prior notice.

→ Optional features