

# PK 4501 / PK 5001-EH

*High Performance*

**PALFINGER CRANE**

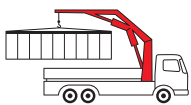

**KTL**  
protected

**Paltronic  
50**  
controlled

**RRC** <sup>→</sup>  
Radio Remote Control  
operated

**ISC** <sup>→</sup>  
Integrated Stability Control  
monitored

**AOS** <sup>→</sup>  
Active Oscillation Suppression  
inside

Efficient all-rounders



## Optimum use of payload

The four hydraulic boom extensions of the PK 4501 provide for an enormous outreach in its class while the low dead weight ensures a wide range of applications. Even large loads can be moved effortlessly due to its optimum ratio of lifting power to dead weight. The PK 5001 EH with HPLS technology combines compact construction with outstanding performance data.





## Manoeuvrable cranes for lightweight trucks



# Operator-friendly



## Knuckle joint on knuckle boom

The knuckle joint significantly improves the crane's motion geometry.



## Maintenance-free extension system

With the maintenance-free extension system PALFINGER sets a clear path in easy servicing. The use of sliding elements made of special plastic in combination with the proven KTL cathodic dip painting means that the extension boom system no longer has to be serviced by the operator. This not only saves time and expense but also protects the environment.



## Control console

All important information about the crane can be seen on the main control stand. A digital indicator counts and displays the operating hours. Ergonomic control levers and the optional lighting package provide increased safety and comfort even in poor visibility conditions.



## Lighting package (optional)

The control stand is supplied on request with LED illumination and backlit symbols. LED warning lights are fitted on the outriggers to provide better visibility.



## Functional Design

Functional Design elements increase working comfort, protect against damage and make servicing and maintenance easier. The spiral tube hose optimally protects the hydraulic hoses from environmental influences, damage and dirt.



## Radio remote control

Radio remote control with digital data transmission (standard on EH models) offers maximum efficiency and comfort. The display integrated in the handset informs the crane operator continuously about the current capacity loading level of the crane.

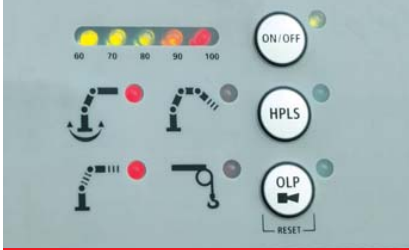

## PALTRONIC 50

Modern electronics in the increasingly complex crane system offers safety and comfort functions which make the crane operator's work easier and increases the efficiency of the crane job.



## Flexible and innovative

### Outrigger system

All the outriggers are fitted as standard with a ball-jointed support plate that can be swivelled through 10°. This enables them to adapt optimally to the ground. The enlarged plate also reduces the pressure on the ground. The PK 4501 and 5001 EH *High Performance* fit onto all standard truck chassis frames. Three outrigger widths are available: 2.9 m, 9'6" (mechanical), 4.4 m, 14'5" (mechanical or hydraulic) and 5.0 m, 16'5" (hydraulic).



### Load-holding valve

They prevent the crane boom from dropping and are fitted as standard on all slewing, lifting, knuckle-boom and extension cylinders. The valves are positioned in such a way that they are protected against damage.

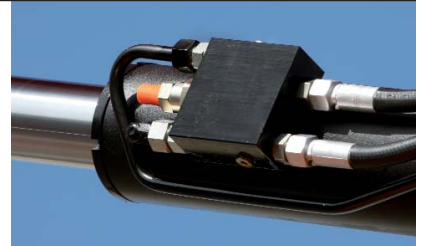

### Hose equipment for auxiliary equipment

Hoses providing oil supply for auxiliary equipment are routed in compact trays and protective chains. A clean design offers maximum service life.



### Return oil utilisation

The high speed of the extension system is impressive. It results from return oil utilisation, which is installed as standard, and the generously dimensioned hydraulic lines. This increases efficiency in all types of applications!



### KTL – the cathodic dip painting

The shot-blasted crane parts are covered in zinc phosphate in an immersion process and coated electro-statically. The subsequent two-component top coating of paint provides a surface protection which in the past was usually only found in the automotive industry.



### ISC (optional)\*

The integrated stability control (ISC) is a system that monitors the stability of the crane vehicle. The system adjusts the crane's lifting forces depending on the current stability support situation and the crane boom to ensure the vehicle's stability over the entire working area.

\* ISC or an alternative system for monitoring stability is mandatory in the version compliant with EN12999:2009.



### AOS (optional)

The Active Oscillation Suppression system available exclusively from PALFINGER compensates for jolts and sharp stress cycles caused by crane operation. Because oscillations are eradicated the crane can work with precision, much faster and therefore more cost-efficiently.



# PK 4501 High Performance

## Max. lifting capacities

### STD

Max. lifting capacities		3300 kg	7270 lbs
Outreach		Capacity	
hydraulic			
3.4 m	11' 2"	1320 kg	2900 lbs
5.2 m	17' 1"	860 kg	1880 lbs

### A

Max. lifting capacities		3200 kg	7050 lbs
Outreach		Capacity	
hydraulic			
3.5 m	11' 6"	1240 kg	3550 lbs
5.2 m	17' 1"	790 kg	2300 lbs
7.1 m	23' 4"	580 kg	1700 lbs

### B

Max. lifting capacities		3150 kg	6940 lbs
Outreach		Capacity	
hydraulic			
3.5 m	11' 6"	1160 kg	2600 lbs
5.3 m	17' 5"	730 kg	1600 lbs
7.2 m	23' 7"	510 kg	1140 lbs
9.0 m	29' 6"	400 kg	880 lbs
manual			
11.0 m	36' 1"	310 kg	680 lbs
12.6 m	41' 4"	220 kg	490 lbs

### C

Max. lifting capacities		3100 kg	6830 lbs
Outreach		Capacity	
hydraulic			
3.6 m	11' 10"	1100 kg	2450 lbs
5.4 m	17' 9"	670 kg	1480 lbs
7.3 m	23' 11"	460 kg	1000 lbs
9.1 m	29' 10"	340 kg	760 lbs
11.0 m	36' 1"	280 kg	610 lbs
manual			
12.5 m	41' 0"	220 kg	490 lbs

### STD

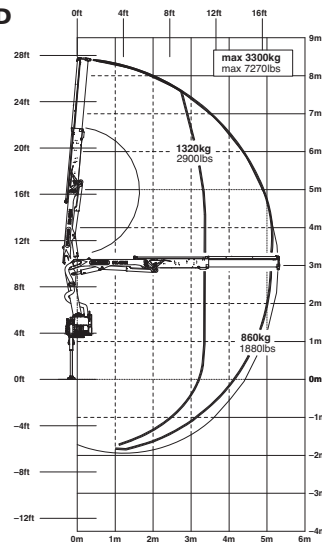

### A

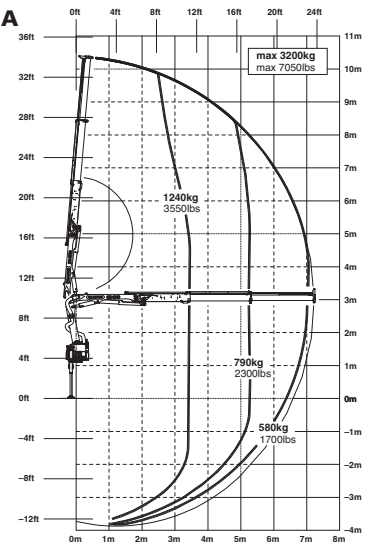

### B

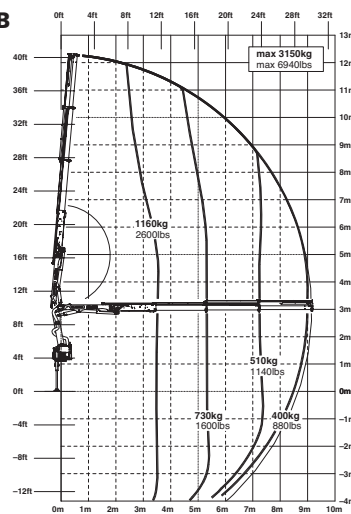

### C

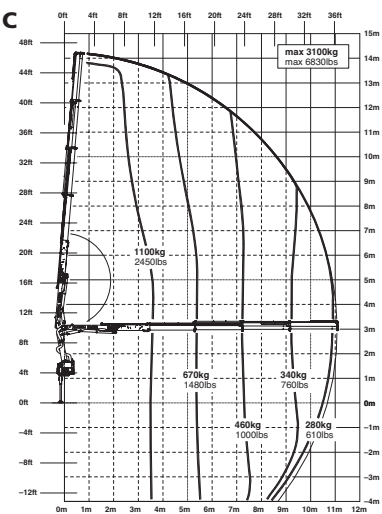

The outreaches stated are with a boom angle of 20° and are therefore not the maximum.

# PK 5001 EH High Performance

**STD**

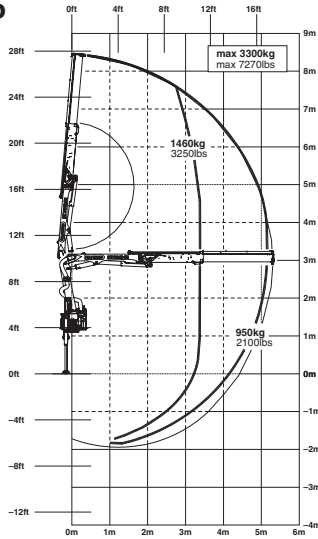

**A**

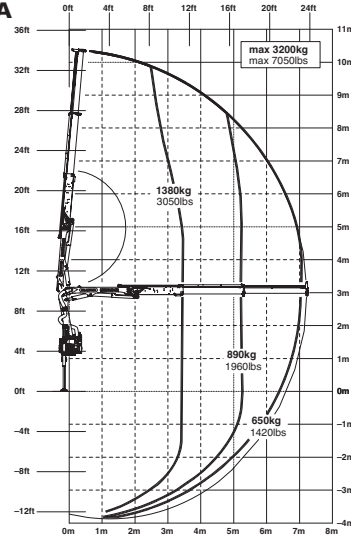

## Max. lifting capacities

**STD**

Max. lifting capacities		3300 kg	7270 lbs
Outreach	Capacity		
hydraulic			
3.4 m	11' 2"	1460 kg	3250 lbs
5.2 m	17' 1"	950 kg	2100 lbs

**A**

Max. lifting capacities		3200 kg	7050 lbs
Outreach	Capacity		
hydraulic			
3.5 m	11' 6"	1380 kg	3050 lbs
5.2 m	17' 1"	890 kg	1960 lbs
7.1 m	23' 4"	650 kg	1420 lbs

**B**

Max. lifting capacities		3150 kg	6940 lbs
Outreach	Capacity		
hydraulic			
3.5 m	11' 6"	1300 kg	2900 lbs
5.3 m	17' 5"	820 kg	1800 lbs
7.2 m	23' 7"	590 kg	1280 lbs
9.0 m	29' 6"	460 kg	1000 lbs
manual			
11.0 m	36' 1"	330 kg	730 lbs
12.6 m	41' 4"	220 kg	490 lbs

**C**

Max. lifting capacities		3100 kg	6830 lbs
Outreach	Capacity		
hydraulic			
3.6 m	11' 10"	1240 kg	2750 lbs
5.4 m	17' 9"	760 kg	1680 lbs
7.3 m	23' 11"	530 kg	1160 lbs
9.1 m	29' 10"	400 kg	880 lbs
11.0 m	36' 1"	330 kg	720 lbs
manual			
12.5 m	41' 0"	220 kg	490 lbs

**B**

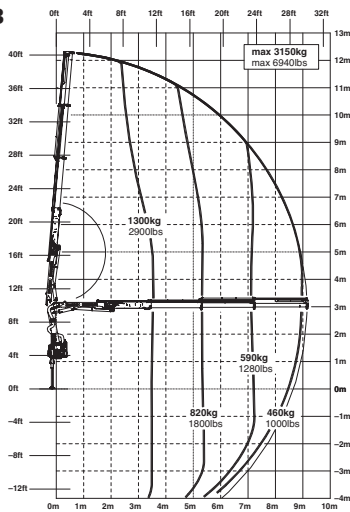

**C**

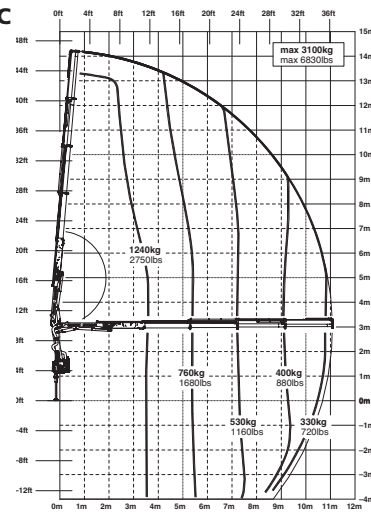

### Package model PK 5001 EH:

- E-HPLS
- Paltronic 50
- Radio remote control with LED display
- Danfoss control valve or PVG2000
- 75 l oil tank

# High performance technology

## PK 4501 High Performance

### Technical Specifications (EN 12999 HC1 HD4/B3)

Max. lifting moment	4.4 mt/43.2 kNm	31840 ft.lbs
Max. lifting capacity	3300 kg/32.4 kN	7270 lbs
Max. hydraulic outreach	11.1 m	36' 5"
Max. manual outreach	12.7 m	41' 8"
Slewing angle	400°	
Slewing torque	0.6 mt/5.9 kNm	4340 ft.lbs
Stabilizer spread	std. 2.9 m/9' 6"	max. 5.0 m/16' 5"
Fitting space required (std.)	0.66 m	2' 2"
Width folded	2.10 m	6' 11"
Max. operating pressure	320 bar	4640 psi
Recommended pump capacity	from 15 l/min	4.0 US gal./min
	to 25 l/min	6.6 US gal./min
Dead weight (std.)	698 kg	1540 lbs

## PK 5001 EH High Performance

### Technical Specifications (EN 12999 HC1 HD4/B3)

Max. lifting moment	4.9 mt/48.1 kNm	35450 ft.lbs
Max. lifting capacity	3300 kg/32.4 kN	7270 lbs
Max. hydraulic outreach	11.1 m	36' 5"
Max. manual outreach	12.7 m	41' 8"
Slewing angle	400°	
Slewing torque	0.6 mt/5.9 kNm	4340 ft.lbs
Stabilizer spread	std. 2.9 m/9' 6"	max. 5.0 m/16' 5"
Fitting space required (std.)	0.66 m	2' 2"
Width folded	2.10 m	6' 11"
Max. operating pressure	350 bar	5075 psi
Recommended pump capacity	from 20 l/min	5.3 US gal./min
	to 30 l/min	7.9 US gal./min
Dead weight (std.)	708 kg	1560 lbs

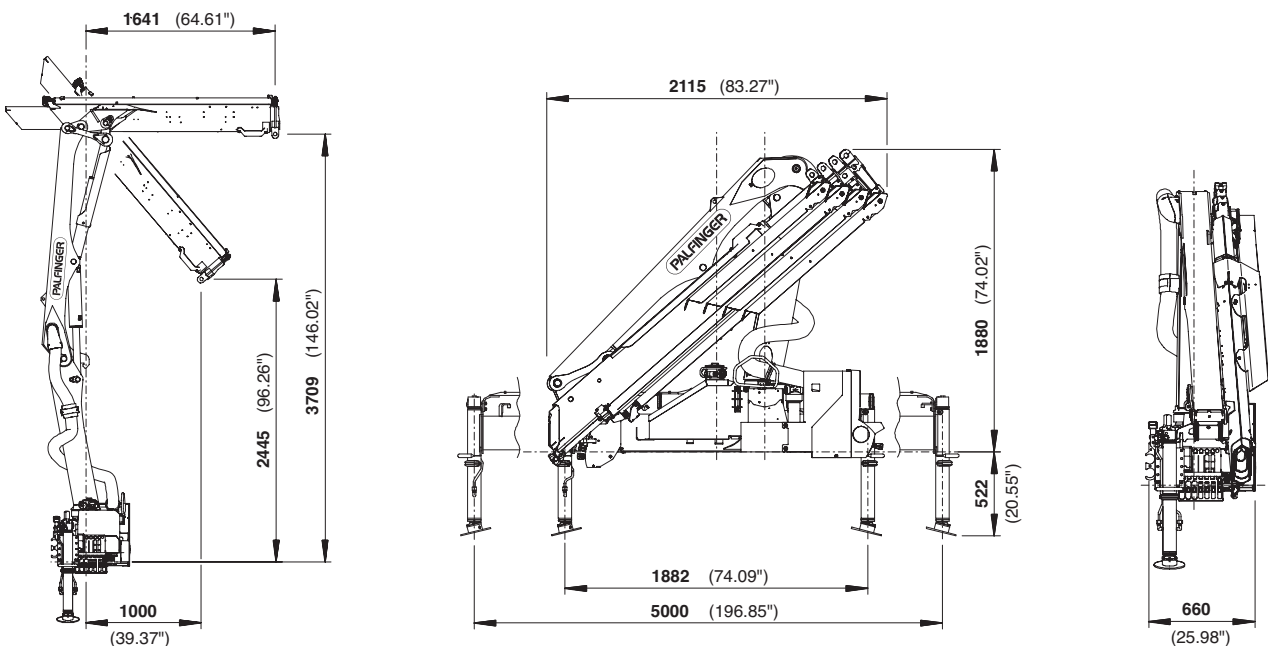
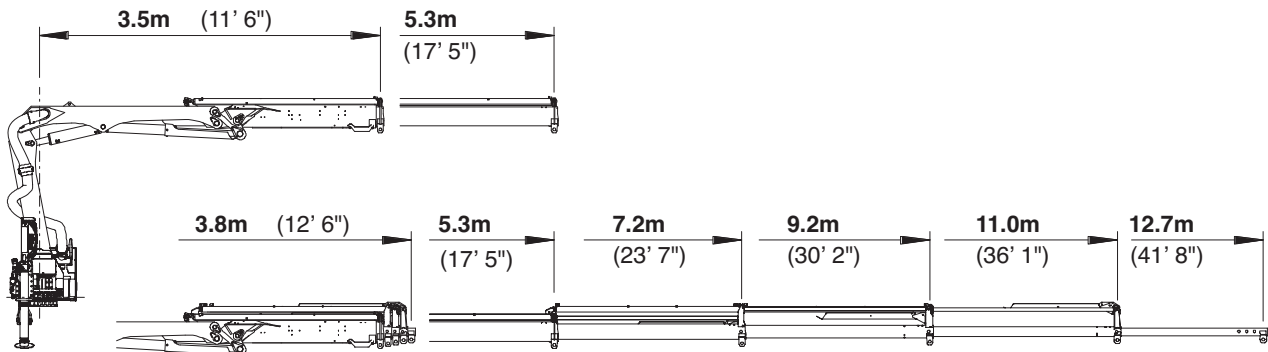

www.palfinger.com

Applications shown in the leaflet do not always correspond to the standard specifications. Design and specification are subject to change without prior notice. Dimensions may vary. Subject to technical changes, errors and translation mistakes.

\*) Optional features/country-specific equipment